

## CONTENT

1. Introduction .....	4
2. Installation .....	8
3. Operating instruction .....	13
4. Reprocessing .....	19
5. Troubleshooting .....	27
6. Storage, maintenance and transportation .....	29
7. Maintenance .....	29
8. After-sale service .....	30
9. Symbols description .....	31
10. Product disposal .....	33
11. Manufacturer's rights .....	36
12. Electromagnetic compatibility .....	36
13. Index: Table of tip power for use .....	44
14. Index: System schematic diagram .....	45

## Copyright & Declaration

Copyright © URIT Medical Electronic Co., Ltd. All rights reserved.

**This document is an English translation of the original Chinese version.**

Congratulations on your purchase of DA-10 from URIT Medical Electronic Co., Ltd. It will bring you a new experience and convenience.

The manual is compiled in accordance with the relevant laws and regulations of China and the specific conditions of the DA-10 manufactured by URIT Medical Electronic Co., Ltd.

The manual includes the latest information as of the time of printing. URIT Medical Electronic Co., Ltd. is solely responsible for the revision and explanation of the simplified Chinese version of the manual, and reserves the right to change the relevant content after the manual is printed without prior notice. The pictures involved in this manual are schematic diagrams and are for reference only. If the pictures do not match the actual product, the actual product shall prevail.

All materials in this manual are protected by copyright law. Without the prior written consent of URIT Medical Electronic Co., Ltd., any form of reproduction, photocopying, or

translation of any content in the manual is not allowed to be translated into other languages.

The operator must strictly follow this manual to operate. Otherwise, URIT Medical Electronic Co., Ltd. shall not be responsible for any errors and equipment failures caused by illegal operations.



**NOTICE:** URIT Medical Electronic Co., Ltd. does not promise that the device will be used for a certain special purpose and make any implied guarantee for its marketability and applicability.

If you need after-sales service support, please contact URIT Medical Electronic Co., Ltd. or an authorized agent.

## **1. Introduction**

### 1.1. Overview

DA-10 adopts piezoceramic ultrasonic technology, which is designed for gingival, subgingival cleaning and root canal washing and has the following characteristics:

- The handpiece can be sterilized at 134°C temperature and 0.22 MPa pressure.
- The product service life is 10 years.

## 1.2. Equipment description

The product is mainly composed of function control circuit, irrigation system, tips, handpiece, and foot switch.

## 1.3. Intended use

- This device is a piezo-operated ultrasonic device for use in dental applications. It is mainly used for the treatment of periodontal defects. In addition, the device is used in the area of prophylaxis, peri-implantitis treatment as well as dental hygiene.
- Intended patient population: Adults and pediatrics patients with periodontal disease and peri-implantitis.
- Pediatrics: Age levels ranged from 12 to 18 years.
- Intended user: The Ultrasonic Scaler is intended to be operated by trained dentist.
- Place of use: professional dental clinics and hospitals.

## 1.4. Contraindications

- Patients with cardiac pacemakers
- Patients with gingival malignant tumor
- Patients with active angina pectoris, myocardial infarction within six months, and uncontrolled hypertension and heart failure

- Patients with local oral inflammation in the acute phase (except acute necrotizing gingivitis)
- Patients with bleeding diseases
- Patients with acute infectious diseases
- Pregnant

### 1.5. Technical parameters

- Input Voltage: 230 V~, 50Hz
- Input Power: 35 VA
- Tip amplitude:    minimum, 1  $\mu\text{m}$ , deviation -50%  
                          maximum, 100  $\mu\text{m}$ , deviation +50%
- Output half-excursion force:    minimum, 0.1 N, deviation -50%  
  maximum, 5 N, deviation +50%
- Tip vibrating frequency: 18 kHz~45 kHz

Note: The vibration frequencies of different types tips are different, but they are all distributed within the described range.

- Output Power of tip: 3 W~20 W
- Fuse: T1AH250V
- Weight: 1.5 kg

- Operation modes: Continuous running
- Protection against electric shock rating: Class II equipment
- Protection against electric shock degree: Type B applied part
- Ingress protection rating : Ordinary equipment (IPX0), Wired foot switch is waterproof equipment (IPX1)
  - Degree of safety application in the presence of a flammable anesthetic mixture with air, oxygen, or nitrous oxide: Non-AP, APG type equipment
    - Pressure of water supply: 0.1 bar~5 bar (0.01 MPa~0.5 MPa)
    - Water output: <50mL/min, under 0.1 bar~5 bar (0.01 MPa~0.5 MPa)
    - Software version: V1

#### 1.6 Operation environment

- a) Ambient temperature: 5 °C~ 40 °C
- b) Relative humidity: ≤80%
- c) Atmospheric pressure: 70 kPa~106 kPa
- d) Applicable range of power supply voltage : 230 V

## 2. Installation

### 2.1. Front/Back view

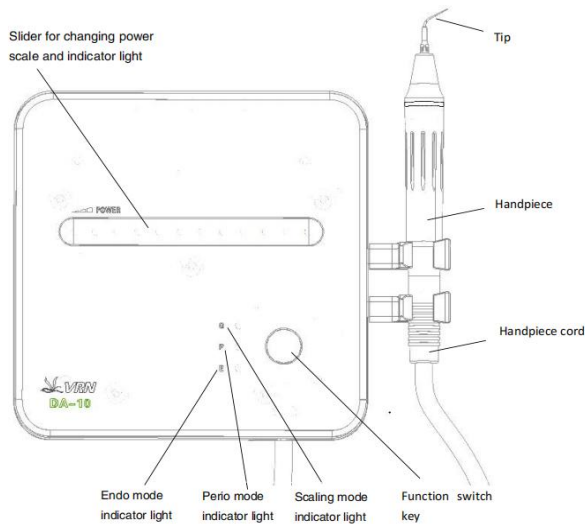

Figure 2.1

### 2.2. Connection of the accessories

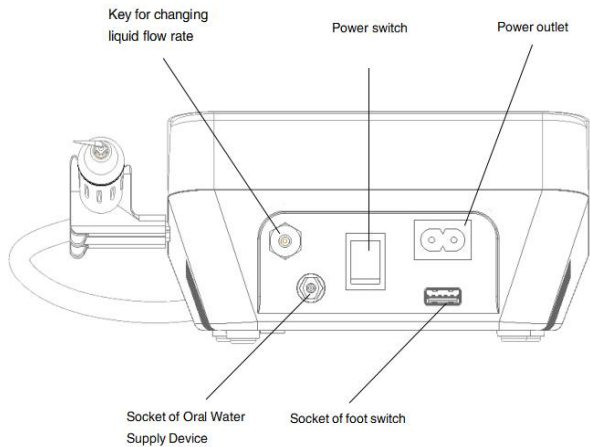

Figure 2.2

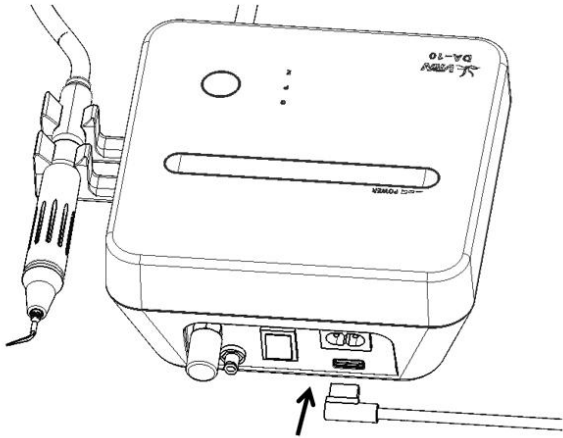

Figure 2.3

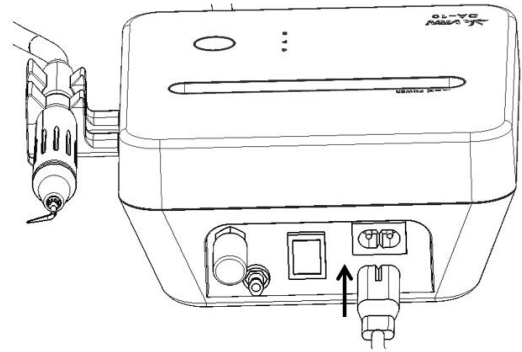

Figure 2.4

### 2.3. Irrigation system

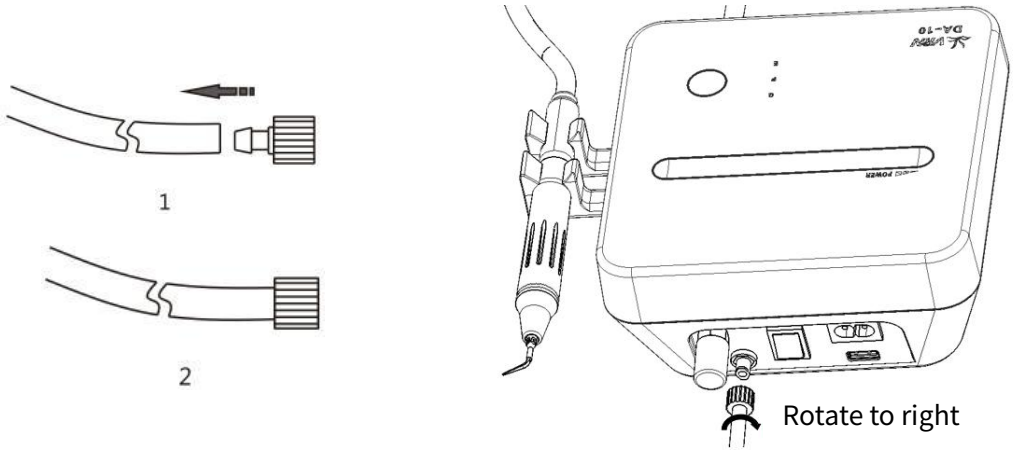

Figure 2.5

## 2.4. Handpiece installation

1. Conehead
2. Ring
3. Handpiece
4. Handpiece cord

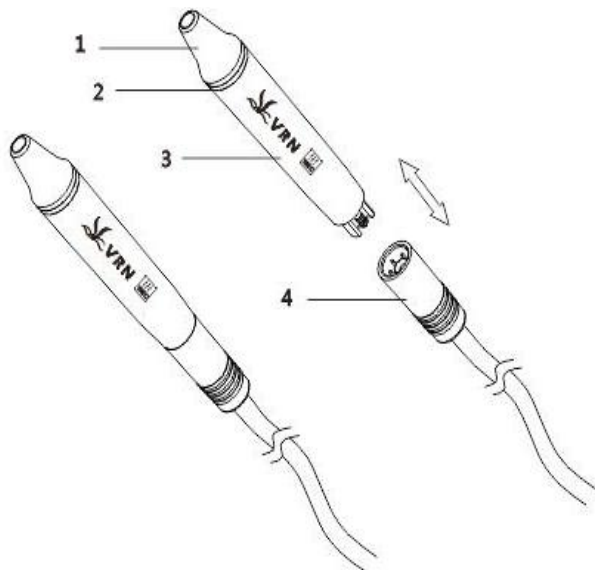

Figure 2.6

## 2.5. Tip installation

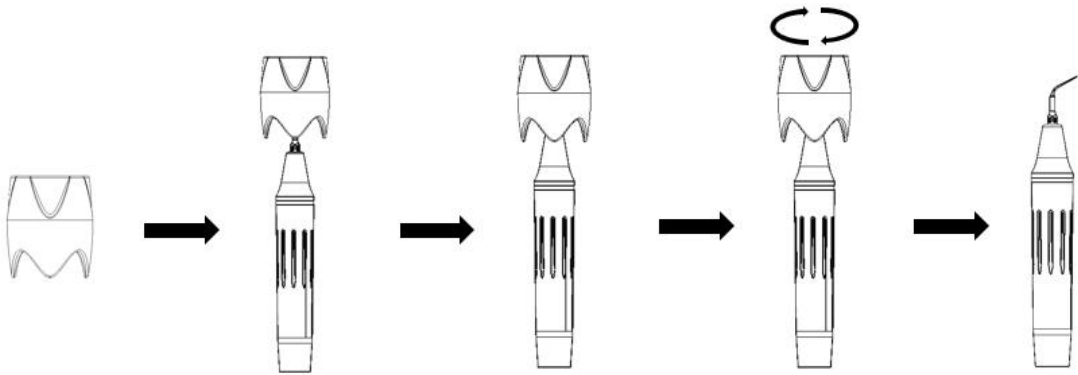

Figure 2.7

### 3. Operating instruction

#### 3.1. Major components of handpiece

Conehead: it can be unscrewed, users can take out the conehead regularly and clean the main pole with alcohol.

Handpiece: it is the important parts of the device, which can be at high temperature and high pressure environment.

Handpiece cord: it is used for connecting the handpiece and irrigation system and circuit of the device.



#### **NOTICE:**

- 1) **Please keep the handpiece and socket dry.**

#### 3.2. Torque wrench

The design of torque wrench adopts a special structure, which can ensure the user can effectively load and unload the tip and protect the user's hand during use, and it can avoid be scratched by the tip when load and unload the tip(See Figure 2.7):

- 1) Put the tip into the wrench.
- 2) Install the tip:hold the handpiece tightly, rotate the tip in a clockwise direction till the tip does not turnround anymore, and then it is installed.

- 3) Unload the tip: hold the handpiece and rotate the tip in a counter-clockwise direction by wrench to remove it.
- 4) Once after using, please put the wrench into sterilization cabinet to sterilize.
- 5) After sterilization, due to the high surface temperature of the torque wrench, the wrench needs to be cooled before it can be used again to avoid burns.
- 6) When the torque wrench is not in use, place it in a ventilated and dry place and keep it clean.

### 3.3. Scaling function for gingiva and subgingival

- 1) Open the package and check whether the accessories of the product are complete according to the packing list. Take out the device from the box and place it on a stable surface facing the operator.
- 2) Set the slider for changing liquid flow rate to the max scale.
- 3) Insert the plug of the wired foot switch into the foot switch socket(See Figure 2.3).
- 4) Connect the connector of liquid pipeline to the device, and input pure water to it(See Figure 2.5).
- 5) Fasten the tip to the handpiece with torque wrench (See Figure 2.7), and then

correctly connect the handpiece with the handpiece cord socket. Before installing the handpiece, dry the connection end of the handpiece and the socket thoroughly(Figure 2.6).

6) Power off the device, then connect the output of the power cord to the device, and then connect the input of the power cord to the electric supply(See Figure 2.4).

7) Power on the device, and the “G” indicator light and the first 3 power indicator lights will light up at this time.

8) The operator selects the "G" and "P" modes according to the series of the tips, and the power of the tip is shown in the attached table.

9) The frequency is relatively fast when the product is working normally, ensure that the device has normal water output, only light touch and reciprocating movement at a certain speed can be used to eliminate dental calculus, and there is no obvious feeling of heating at the tip; Excessive local force or staying for too long when cleaning teeth.

10) Vibration intensity: adjust the vibration intensity according to your needs. Generally, user can adjust it to a medium vibration intensity. User can also adjust the vibration intensity at any time during the clinical process according to the patient's

sensitivity and the hardness of the calculus.

11) Liquid flow rate: step on the foot switch, the tip will vibrate, slide the liquid slider to make the liquid into a semi-atomized state to cool the tip and clean the teeth.

12) Generally use the pen position to hold the handpiece.

13) During scaling, do not make the tip be in vertical contact with the teeth, and do not apply heavy pressure to avoid damage to the teeth and tip.

14) After completing scaling, keep working for 30 seconds under the water supply to clean the handpiece and tip.

15) Remove the tip and then pull out the handpiece for sterilization.



NOTICE:

1) Please do not pull out the handpiece when stepping on the foot switch and the tip vibrates.

2) Please do not move or turn over the device when it is working.

### 3.4. Endo function

1) Fix the holder of endo file to the handpiece with endo wrench.

2) Unscrew the nut of the holder .

- 3) Insert the endo file into the hole in front of the holder.
- 4) Tighten the nut of the endo file with endo wrench.
- 5) Press "E", the "E" indicator lights up.
- 6) When the Endo function is selected, slowly extend the endo file into the patient's root canal, step on the foot switch and start the root canal washing. Adjust the power of root canal washing as needed.
- 7) After finishing the treatment, unscrew the nut of the endo file holder, take out the file, remove the endo file holder and the handpiece for sterilization.



**NOTICE:**

- 1) Tighten the endo tip.
- 2) Tighten the nut of the holder.
- 3) Do not apply heavy pressure when root canal washing.
- 4) Do not step on the foot switch when the endo file is not placed in the root canal.
- 5) It is recommended that the power adjustment start from the 1st scale and slowly increase to the 3rd scale when using the Endo function.
- 6) Please do not move or turn over the device when it is working.

### 3.5. Precautions

- 1) Keep the device clean and dry before or after use.

- 2) Prohibit suspended or inverted device.
- 3) Before each use, please let the device work for 30 seconds under the condition of water to remove the residual water in the pipeline.
- 4) The operator should be equipped with adequate protection (such as goggles, mask, etc.) to prevent cross-infection.
- 5) Using the product must comply with the requirements of the relevant operating specifications and relevant laws and regulations of the medical department, and it is limited to trained doctors or technicians.
- 6) Before each use, please sterilize the tip, wrench and other accessories.
- 7) Don' t tighten or loosen the tips when the handpiece is activated.
- 8) Tighten the tips.
- 9) When the tip is damaged or worn, the vibration intensity will decrease. The operator should replace the tip with a new one according to the clinical situation.
- 10) Don' t bend or sharpen the tips.
- 11) Don' t use unclean water, and do not use normal saline instead of pure water sources.
- 12) Don' t pull the tail wire forcefully during the use to avoid damage to the tail wire.
- 13) Don' t beat and scrape the handpiece in a hurry.

14) After using the device, power off the device and pull out the power plug.

15) Our company specializes in producing medical devices and we're responsible for its secVRNy only when the device maintained, repaired and modified by VRN or Distributor authorized by the our Company, and the replacement accessories are made by our Company and operating follow the user manual.

16) The internal thread of the tips produced by some manufacturers is rough, rusty, chipped or adopts other standard threads. When used with the handpiece, it is easy to damage and slip the teeth, and even cause irreparable damage to the product. Please use the original tip.

17) When the operator uses a different series of tips, it needs to adjust the working mode accordingly to avoid breaking the tip.

18) Don' t move or flip the device during use.

#### **4. Reprocessing**

The instructions provides instructions for cleaning, sterilization and packaging of Ultrasonic Scaler intended to be reprocessed in medical facilities.Reprocessing components include tip,wrench and handpiece.

The goal of reprocessing reusable products is to reduce bioburden and to achieve sterility of those products in order to eliminate the risk of product reuse related infection. Decisions regarding cleaning or sterilizing dental instruments are based on the potential risk of infection associated with their use.

It is recommended to use steam sterilization. Remember that sterilization cannot be achieved unless the elements of the assembly are cleaned first.

If there is anything in the following instructions that is not clear, do not hesitate to contact.

We encourage you to report adverse events related to device reprocessing. Report such events directly to URIT Medical Electronic Co., Ltd.

#### **4.1 Reprocessing instructions for reusable products**

The instructions are binding for the reprocessing of Ultrasonic Scaler. When necessary, additional product-specific instructions are included with the product to provide additional information.

Before use, carefully read the operating instructions of Ultrasonic Scaler and devices with which the product will be used. Reusable products must be cleaned and sterilized prior to

first use. They must be replaced after the number of operations specified by the manufacturer. Disposable products (single use) cannot be reused.

## **4.2 Preparation**

It is only possible to carry out effective sterilization after the completion of effective cleaning. Please ensure that, as part of your responsibility for the sterility of products during use, only sufficiently validated equipment and product-specific procedures are used for cleaning and sterilization, and that the validated parameters are adhered to during every cycle. Please also observe the applicable legal requirements in your country as well as the hygiene regulations of the hospital or clinic.

## **4.3 Initial treatment at the point of use**

The treatment must be carried out immediately, no later than 30 minutes after the completion of the operation. Additional information, where necessary, is provided in the respective product-specific usage instructions.

### **Steps**

- 1) Completely disassemble the tips and handpiece from Ultrasonic Scaler, if applicable. Rinse away any surface soiling of them with distilled deionized water or cleaning agent.

- 2) Rinse through all lumina (e.g. irrigation and aspiration connection) at least 3 times in the normal direction of flow (no back rinsing) using a disposable syringe (min. volume 50 ml) filled with distilled/deionized water applied to the back nozzle.
- 3) An aldehyde-free cleaning and disinfection solution that is compatible with the products may also be used as an alternative rinsing solution. In such cases, it is necessary to rinse thoroughly afterwards at least 3 times with distilled, or deionized water.

## 4.4 Cleaning

### Preparation

When selecting the cleaning agent to be used, ensure that:

- These are fundamentally suitable for the cleaning of the products and compatible with one another,
- The chemicals used are compatible with the products.

 It is absolutely essential that the concentrations and contact times specified by the manufacturer of the cleaning agent are adhered to. Only freshly prepared solutions may be used. The solution is not permitted to foam. Only sterilized or low microbe count distilled/deionized water (< 10 cfu/ml) can be used for all rinsing steps.

## Steps for manual cleaning

- 1) Completely disassemble the handpiece and instruments, if applicable.
- 2) Place the products in 75% ethyl alcohol for at least 3mins.
- 3) Remove any externally-attached soiling by brushing carefully with a soft brush or a soft cloth for at least 3 mins.
- 4) Rinse the products vigorously at least five times, each time with fresh distilled or deionized water (each product lunmen with at least 50 ml of water). Repeat the cleaning process if the last rinsing does not run clear, or if stains are still visible on the product.

 The product adopts manual cleaning and it has been verified. Please do not modify the cleaning method without authorization, such as using disinfectant for automated cleaned.

**Notice: No automatic cleaning for the product.**

### 4.5 Drying

After cleaning, put the handpiece, wrench and tips into the oven for drying. The recommended drying condition is 138°C for 20 minutes.

### 4.6 Inspection and maintenance

 If stains are still visible on the product after cleaning, the entire cleaning procedure

must be repeated. Products with visible damage, chip/flake loss, corrosion or bent out of shape must be disposed of (no further use is permissible).

#### **4.7 Packaging**

Only cleaned products are permitted to be sterilized. Prior to sterilization, the products need to be placed in a suitable sterilization container:

- Resistant to 138°C, with adequate steam permeability,
- Maintained on a regular basis.

If single-use sterilization packaging is to be used, this must be suitable for steam sterilization (temperature resistant to 138°C with adequate steam permeability). The material of sterilization packaging is made of medical paper and PET/PP. The packaging material complies with the requirements of EN ISO 11607-1.

#### **Steps**

- 1) Select a suitable sterilization packaging according to the size of the sterilized item and put the items in.
- 2) Place the sharp and specially shaped devices in the correct position for safe removal when opened.
- 3) Affix the strip of sterilization packaging (the strip of the packaging is sticky and it does not require additional processing for sealing such as heat sealing) and mark the

sterilization time.

- 4) Put the sealed sterilization packaging rightly into steam sterilizer.
- 5) Pay attention to the color-changing: if sterilization is really implemented, it will turn black /grey from initial blue under steam sterilization.
- 6) Open the strip along the direction printed on the packaging and then takes the items out.

#### **4.8 Sterilization**

The handpiece and tips can withstand 250 reprocessing cycles. Do not exceed the maximum number of reprocessing cycles.

Use only the following listed steam sterilization procedures for sterilization; other sterilization procedures are not permissible:

- Steam sterilizer in accordance with EN 13060 validated in compliance with EN ISO 17665,
- Maximum sterilization temperature 138°C.

#### **Steps for sterilization**

1. Sterilization at 134°C for 4 minutes.
2. Sterilization at 134°C for a maximum of 20 minutes is permissible.

The hot-air sterilization and radio-sterilization procedure may not be used (as it causes

the destruction of products). The manufacturer assumes no responsibility for the use of other sterilization procedures (e.g. ethylene oxide, formaldehyde and low temperature plasma sterilization).

#### **4.9 Service life**

The handpiece and tips have been designed for 250 reprocessing cycles. Ultrasonic Scaler has 10 years service life and tips have 5 years service life from start with production, if it exceeds reprocessing cycles or service life, it should be not used any more. The materials used in their manufacture were selected accordingly. However with every renewed preparation for use, thermal and chemical stresses will result in ageing of the products. The use of ultrasound baths and strong cleaning and disinfection fluids (alkalizing pH > 9 or acid pH < 5) can reduce the life span of products. The manufacturer accepts no liability in such cases. The products may not be exposed to temperatures above 138°C.

#### **4.10 Storage and transportation**

After sterilization, keep sterilization packaging and stored it in the following environment to avoid infection and sterilization failure:

- Temperature: -20 °C to 55 °C,
- Humidity: ≤95%,
- Atmospheric pressure: 70kPa~106 kPa.

⚠ The product can keep sterile for 6 months in sterilization packaging, when exceed the 6 months, it shall be reprocessed again before use.

After reprocessing, it is necessary to confirm that the products can work normally before use. If products with visible damage, chip/flake loss, corrosion, rust or bent out of shape must be disposed of (no further use is permissible).

## 5. Troubleshooting

Error	Possible causes	Solutions
Turn on the power switch, there is no indicator light on the panel	Poor contact of power plug	Plug in the power plug tightly
	Internal fuse not working	Contact your local dealer or our company
There is no vibration after stepping on foot switch	Poor contact of wired foot switch	Plug in the plug of foot switch tightly
After stepping on the foot switch, the	Tip loose	Fasten the tip using the wrench
	Faulty handpiece	Pull out handpiece and contact your

	Faulty handpiece cord or inside circuit	Contact your local dealer or our company
There is water spray	Faulty electromagnetic	Contact your local dealer or our
Handpiece	Faulty handpiece	Pull out handpiece and contact your
Handpiece	Faulty handpiece	Pull out handpiece and contact your
Inadequate amount of spray	Spray is set up too small	Adjust the spray
	The water circuit is	Unblock the water circuit by three-ways
Weak tip vibration	Tip loose	Fasten the tip using the wrench
	There is not dry between	Dry the connector between the base of
	Worn or bent tip	Replace the tip
Water is leaking between the base of the handpiece and its	Wear of the seal	Replace the seal
There is no vibration or noisy at root canal file	Loose clamping nut	Tighten clamping nut
	Damaged root canal holder	Replace root canal holder

**NOTICE: If the fault still cannot be resolved, please contact your local dealer or our company.**

## 6. Storage, maintenance and transportation

### 6.1. Storage and maintenance

- The device should be handled with care, far away from the earthquake source, and should be installed or stored in a cool, dry and ventilated place.
- Do not mix with toxic, corrosive, flammable and explosive materials during storage.
- When the product is not used for a long time, it should be connected to water and electricity once a month, each time for 5 minutes.
- Store temperature from -20 °C to 55 °C, relative humidity  $\leq 95\%$ , atmospheric pressure from 70 kPa to 106 kPa.

### 6.2. Transportation

- Transport should not be mixed with dangerous goods.
- Avoid excessive shock and vibration during transportation, handle with care and avoid upside-down.
- Keep away from rain, sunlight or snow during transportation.

## 7. Maintenance

No.	Name	Replacement cycle	Replacement Method
1	Main board	/	/
2	Touch keyboard	/	/















3	Handpiece	250 reprocessing cycle	See article 3.4
4	Handpiece cord	/	/
5	Tips	250 reprocessing cycle/5	See article 3.5
6	Torque wrench	250 reprocessing cycle	/
7	Endo wrench	250 reprocessing cycle	/
8	Endo tips	250 reprocessing cycle	See article 3.5
9	Liquid pipe(4×6mm)	/	/
10	Power cord	/	/
11	Electromagnetic valve	/	/
12	Wire foot switch	/	/















**NOTICE:** There doesn't exhaustively list the accessories and specifications of DA-10. Please refer to the random delivery materials and packing list for details. Should your product need serviced and repairs, please send it to your dealer or to an authorized repair center. We decline responsibility for the safety of the device and declare the warranty null and void if service or repair is carried out by an unauthorized third party or if non-genuine spare parts are used.

## 8. After-sale service

This device is guaranteed by the warranty card from the date of sale, and is responsible for lifetime maintenance. Irreparable device damage caused by non-designated dedicated maintenance personnel is not covered by the free warranty.

## 9. Symbols description

Symbol	Description	Symbol	Description
	Manufacturer's logo		Fuse
	Caution		Slider for changing power scale
	Refer to instruction manual/ booklet		Manufacturer
	“ON” (power)		“OFF” (power)
	Date of manufacture		Use by date
	Temperature Limit		Atmospheric pressure limitation
	Humidity limitation		Serial number

Symbol	Description	Symbol	Description
	This way up		Fragile, handle with care
	Keep away from rain		Class II equipment
	Type B applied part		Medical device
	Sterilization at 134°C in an autoclave		Variability in steps of power
	Foot switch	IPX1	Ingress protection rating
	Do not roll		Stacking limit by number
	CE marking		Unique device identifier
	Authorized representative in the European Community/European		Do not dispose of the product into the ordinary municipal waste or garbage

Symbol	Description	Symbol	Description
	Union		system.

## 10. Product disposal

No.	Components	Disassemble methods	Dispose methods
1	Printed-wiring boards	Use a Phillips screwdriver to remove the fixing screw, unplug the cable, and remove the items.	Recycle as metals and metal compounds. Please put them to the waste sorting recycling bin of metals.
2	Transformer		
3	Pump		1.For metals and metal compounds, please put them to the waste sorting recycling
4	Solenoid valve		

			bin of metals. 2.For nonmetal, please put them to the waste sorting recycling bin of organic substances which are not used as solvents,which can be used for composting and other biological transformation processes.
5	Handpiece cord		Please put them to the waste sorting recycling bin of organic substances which are not used as solvents,which can be used for
6	Enclosure		
7	PU tube	Remove the PU tube with nipper pliers.	
8	Water bottle	Remove from the main unit.	

			composting and other biological transformation processes.
9	Ultrasonic scaler tips	Refer to the section 2.5 in the manual.	Please dispose it in the infectious clinical waste containers.
10	Foot switch	/	1.For metals and metal compounds, please put them to the waste sorting recycling bin of metals. 2.For nonmetal, please put them to the waste sorting recycling bin of organic substances which are not used as solvents,which can be
11	Handpiece	Remove from the handpiece cord.	

			used for composting and other biological transformation processes.
--	--	--	--



- 1. Electrical waste products should not be disposed of with household waste.**
- 2. Please recycle where facilities exist. Check with your local authority or retailer for recycling advice if you are unclear.**

### **11. Manufacturer's rights**

The company reserves the right to modify the design, technology, accessories, user manual content and packing list content of the product at any time without notice. In case of discrepancies, the actual product shall prevail.

### **12. Electromagnetic compatibility**



**NOTICE:**

- 1) Without the express consent of VRN, unauthorized changes or modifications to the device may cause electromagnetic compatibility(EMC) problems of the device or other device.
- 2) The design and test of device comply with the operating regulations related to EMC.
- 3) The ME EQUIPMENT is suitable for hospital and clinics.

Warning: Even if other devices meet the launch requirements of the corresponding national standards,the device or system may interfere with other electronic devices.

**Warning:** Don' t near active HF surgical equipment and the RF shielded room of an ME system for magnetic resonance imaging, where the intensity of EM disturbances is high.

**Warning:** Use of this equipment adjacent to or stacked with other equipment should be avoided because it could result in improper operation.If such use is necessary, this equipment and the other equipment should be observed to verify that they are operating normally.

**Warning:** Use of accessories, transducers and cables other than those specified or provided by the manufacturer of this equipment could result in increased electromagnetic emissions or decreased electromagnetic immunity of this equipment and result in improper operation.

**Warning:** Portable RF communications equipment (including peripherals such as antenna

cables and external antennas) should be used no closer than 30 cm (12 inches) to any part of the equipment, including cables specified by the manufacturer. Otherwise, degradation of the performance of this equipment could result.

**Note:** The emissions characteristics of this equipment make it suitable for use in industrial areas and hospitals (CISPR 11 class A). If it is used in a residential environment (for which CISPR 11 class B is normally required) this equipment might not offer adequate protection to radio-frequency communication services. The user might need to take mitigation measures, such as relocating or re-orienting the equipment.

### 12.1 Cable length

Cable name	Type	Length
Power cord	Unshielded parallel line	1.8 m
Input line of	Unshielded parallel line	2.5 m
Handpiece cord	Unshielded parallel line	2 m

### 12.2 Key components of EMC

The product key components of EMC are the scaler's main board chip, touch board chip, transformer and diaphragm pump. The use or replacement of accessories, cables, transducers,

etc. that are not designed to match will cause the electromagnetic emissions and immunity performance to be significantly reduced. Do not replace device parts without authorization.

### 12.3 Electromagnetic emissions

Guidance and manufacturer' s declaration - electromagnetic emissions	
Emissions test	Compliance
RF emissions CISPR 11	Group 1
RF emissions CISPR 11	Class B
Harmonic emissions IEC 61000-3-2	Comply
Voltage fluctuations/ flicker emissions IEC 61000-3-3	Comply

### 12.4 Electromagnetic immunity

Guidance and manufacturer' s declaration - electromagnetic Immunity
---

<b>Immunity Test</b>	<b>IEC 60601-1-2 Test level</b>	<b>Compliance level</b>
Electrostatic discharge (ESD) IEC 61000-4-2	$\pm 8$ kV contact $\pm 2$ kV, $\pm 4$ kV, $\pm 8$ kV, $\pm 15$ kV air	$\pm 8$ kV contact $\pm 2$ kV, $\pm 4$ kV, $\pm 8$ kV, $\pm 15$ kV air
Electrical fast transient/burst IEC 61000-4-4	$\pm 2$ kV power supply lines $\pm 1$ kV signal input/output 100 kHz repetition frequency	$\pm 2$ kV power supply lines $\pm 1$ kV signal input/output 100 kHz repetition frequency
Surge IEC 61000-4-5	$\pm 0.5$ kV, $\pm 1$ kV differential mode $\pm 0.5$ kV, $\pm 1$ kV, $\pm 2$ kV common mode	$\pm 0.5$ kV, $\pm 1$ kV differential mode $\pm 0.5$ kV, $\pm 1$ kV, $\pm 2$ kV common mode
Voltage dips, short interruptions and voltage variations on power supply input lines IEC 61000-4-11	0 % UT; 0,5 cycle. At $0^\circ$ , $45^\circ$ , $90^\circ$ , $135^\circ$ , $180^\circ$ , $225^\circ$ , $270^\circ$ and $315^\circ$ . 0 % UT; 1 cycle and 70 % UT; 25/30 cycles; Single phase: at $0^\circ$ . 0 % UT; 250/300 cycle	0 % UT; 0,5 cycle. At $0^\circ$ , $45^\circ$ , $90^\circ$ , $135^\circ$ , $180^\circ$ , $225^\circ$ , $270^\circ$ and $315^\circ$ . 0 % UT; 1 cycle and 70 % UT; 25/30 cycles; Single phase: at $0^\circ$ . 0 % UT; 250/300 cycle
Power frequency magnetic field IEC 61000-4-8	30 A/m 50Hz/60Hz	30 A/m 50Hz/60Hz

Conducted RF IEC61000-4-6	3 V 0,15 MHz – 80 MHz 6 V in ISM and amateur radio bands between 0,15 MHz and 80 MHz 80 % AM at 1 kHz	3 V 0,15 MHz – 80 MHz 6 V in ISM and amateur radio bands between 0,15 MHz and 80 MHz 80 % AM at 1 kHz
Radiated RF IEC61000-4-3	10 V/m 80 MHz – 2,7 GHz 80 % AM at 1 kHz	10 V/m 80 MHz – 2,7 GHz 80 % AM at 1 kHz
NOTE $U_T$ is the a.c. mains voltage prior to application of the test level.		

<b>Guidance and manufacturer's declaration - electromagnetic Immunity</b>						
Radiated RF IEC61000-4-3 (Test specifications for ENCLOSURE PORT IMMUNITY to RF wireless communications	Test Frequency (MHz)	Band (MHz)	Service	Modulation	IEC 60601-1-2 Test Level (V/m)	Compliance level (V/m)
	385	380 – 390	TETRA 400	Pulse modulation 18 Hz	27	27

equipment)	450	430 – 470	GMRS 460, FRS 460	FM ± 5 kHz deviation 1 kHz sine	28	28
	710	704 – 787	LTE Band 13, 17	Pulse modulation 217 Hz	9	9
	745					
	780					
	810	800 – 960	GSM 800/900, TETRA 800, iDEN 820, CDMA 850, LTE Band 5	Pulse modulation 18 Hz	28	28
	870					
	930					
	1720	1 700 – 1 990	GSM 1800; CDMA 1900; GSM 1900; DECT; LTE Band 1, 3, 4, 25;	Pulse modulation 217 Hz	28	28
	1845					
	1970					

			UMTS			
	2450	2 400 – 2 570	Bluetooth, WLAN, 802.11 b/g/n, RFID 2450, LTE Band 7	Pulse modulation 217 Hz	28	28
	5240	5 100 –	WLAN 802.11	Pulse modulation	9	9
	5500	5 800	a/n	217 Hz		
	5785					

<b>Guidance and manufacturer's declaration - electromagnetic Immunity</b>				
Radiated RF IEC61000-4-39 (Test specifications for ENCLOSURE PORT IMMUNITY to proximity magnetic fields)	Test Frequency	Modulation	IEC 60601-1-2 Test Level (A/m)	Compliance level (A/m)
	30 kHz	CW	8	8

	134,2 kHz	Pulse modulation 2.1 kHz	65	65
	13,56 kHz	Pulse modulation 50 kHz	7,5	7,5

DA-10 has passed test according to the standard IEC 60601-1-2, but it cannot guarantee in any way that it is not affected by electromagnetic interference. DA-10 should be avoided using in high electromagnetic environments.

### 13. Index: Table of tip power for use

Model	Gear	Irrigation flow	Treatment type
G1	1-10(G)	YES	Supragingivale scaling
G2	1-10(G)	YES	Supragingivale scaling
G4	1-6(G)	YES	Supragingivale scaling

P1	1-10(P)	YES	Subgingival scaling
----	---------	-----	---------------------

## 14. Index: System schematic diagram

